

- EN Shell end mills | fine teeth
- DE Walzenstirnfräser | feingezahnt
- RU Фрезы цилиндрические торцевые | мелкозубые

typ H     $\lambda=25^\circ$      $\gamma=12^\circ$     
 HSSE = litá HSS • cast HSS  
 HHS fondu • литая HSS

## 6309

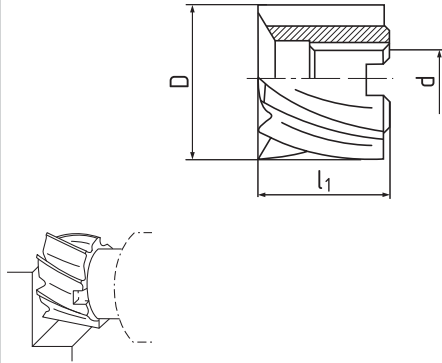

D js 16	d H 7	l <sub>1</sub>	Z	630973
40	16	32	8	.040
50	22	36	10	.050
63	27	40	12	.063
80	27	45	14	.080
100	32	50	16	.100
125	40	56	18	.125
160	50	63	20	.160

### Řezné podmínky / Cutting conditions / Schnittbedingungen / Условия резания

Material	A <sub>p</sub>	A <sub>e</sub>	V <sub>c</sub>	f <sub>z</sub> (mm/z)				
				Ø 40	Ø 50	Ø 80	Ø 100	Ø 160
<b>P.2</b> ≤ 850 N/mm <sup>2</sup>	0,05xD	0,75xD	26	0,080	0,085	0,110	0,110	0,120
<b>P.4</b> ≤ 900 N/mm <sup>2</sup>	0,05xD	0,75xD	20	0,080	0,085	0,110	0,110	0,120
<b>K.2</b> > 240 HB	0,05xD	0,75xD	17	0,080	0,085	0,110	0,110	0,120